

AquaFlow HP

Heat pump indirect
unvented cylinder



- RANGE 200 - 250 - 300 ■
- 25 YEAR WARRANTY ■
- BUILDING & WATER REGULATIONS APPROVED ■
- HIGH QUALITY STAINLESS STEEL ■
- HIGH PERFORMANCE ■

AquaFlow HP

Heat pump indirect unvented cylinder

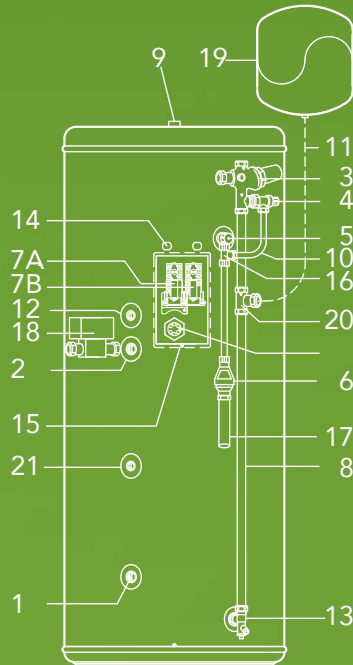

Schematic for 250 & 300 litre only

KEY

1. Return 3/4" BSPF
2. Flow 3/4" BSPF
3. Pressure reducing valve with check valve and balanced bold bonnection
4. Expansion valve
5. Temperature and pressure relief valve
6. Tundish
- 7A. Thermostat immersion heater
- 7B. Thermostat heat pump
8. Cold feed tube
9. Hot water outlet 3/4" BSPF
10. Flexible hose
11. Flexible hose for expansion vessel
12. Sensor pocket 1/2"
13. Elbow / drain cock
14. Cable entry
15. Electrical box
16. Tee piece
17. Discharge pipe
18. Motorized valve M
19. Expansion vessel
20. Tee piece for exp. vessel
21. Sensor pocket 1/2"

SPECIFICATIONS	AQUA FLOW 200 HP	AQUA FLOW 250 HP	AQUA FLOW 300 HP
PRODUCT ORDER CODE	29450029	29450030	29450031
CAPACITY (LITRES)	200	250	300
DIMENSIONS AND WEIGHTS			
HEIGHT (MM)	1160	1410	1610
DIAMETER (MM)	580	580	580
WEIGHT WHEN FULL (KG)	241	292	341
PERFORMANCE			
COIL RATING (kW)	26.9	29.7	27.1
AVERAGE RECOVERY TIME (MIN)	20.8	23	27
EFFICIENCY			
ENERGY LOSS (kWh/DAY)	1.59	1.87	2.08
MAX WORKING PRESSURE (BAR)	8	8	8
ErP RATING	C	C	C

- 3 capacities: 200, 250 and 300 litres.
- Large surface area coil; use with Vokèra AriaPRO air source heat pumps.
- Inner tank guaranteed for 25 years, made from stainless steel.
- 2 year warranty on ancillary parts.
- High performance main pressure to all hot water outlets.
- Up to 50 l/min flow rate.
- Building and water regulations approved.
- No need for 'sacrificial anode' due to excellent anti-corrosion properties.
- Compact dimensions.
- TPRV, EV, Water controls, Tundish, 2-port motorised valve supplied as standard.
- 3kW immersion heater and energy cut-out device supplied as standard.
- Optional secondary return connection if required.
- Thermal insulation and efficient coil meet Part L Requirements.

⁽¹⁾ Subject to registration and annual service, 25 year warranty on the tank, 2 year warranty on ancillary parts.



ErP Compliant



25 Year Warranty⁽¹⁾



BUILDING AND WATER REGULATIONS APPROVED



AriaPRO COMPATIBLE

GET IN TOUCH

Vokèra Limited, Borderlake House, Unit 7 Riverside Industrial Estate, London Colney, AL2 1HG

E: enquiries@vokera.co.uk

W: www.vokera.co.uk

T: 0844 391 0999

F: 0844 391 0998

WE ARE SOCIAL

