

**Wall hung boilers**

**Excel 29**

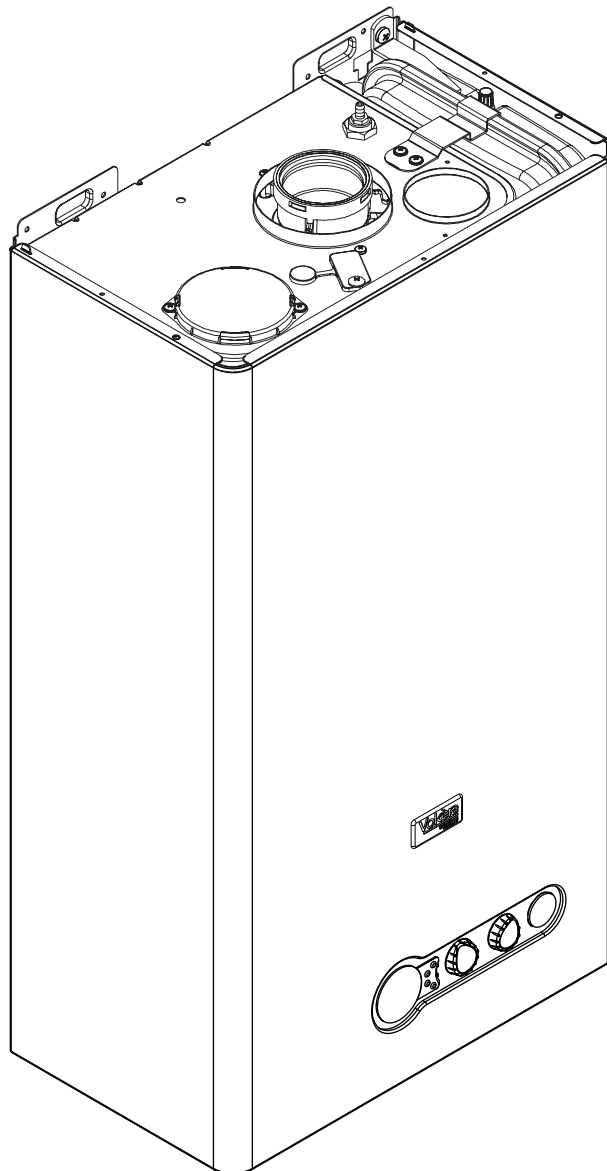

MODEL	PART NUMBER	
	MTN	GPL
Excel 29	20099225	-

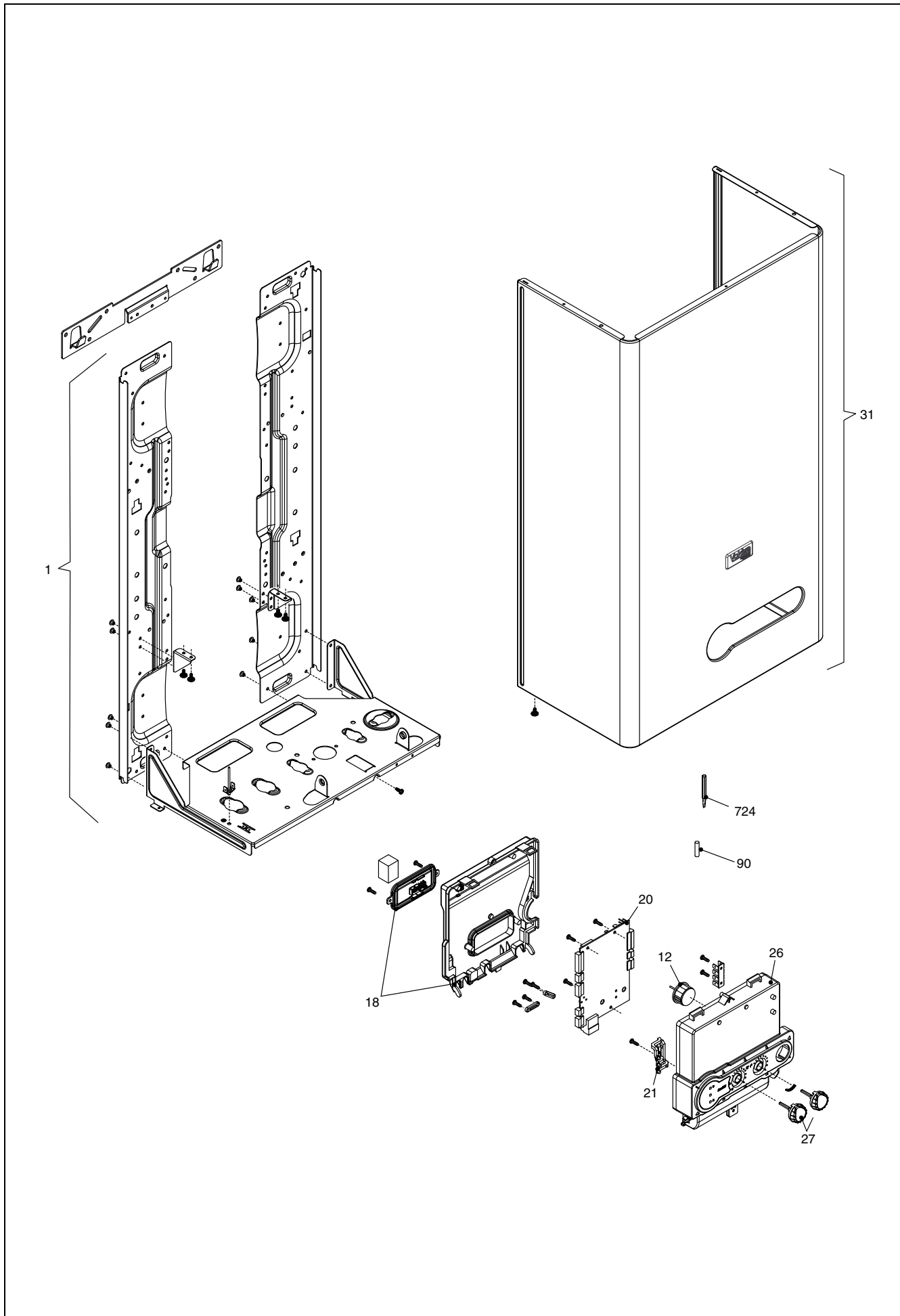

POS.	DESCRIPTION	29
2	Frame assembly	20049618
12	Quick primer pressure gauge	20049617
18	Cover assembly	20057326
20	Printed circuit board AKL03	20069541
21	Led light guide	20057350
26	Control panel	20067812
27	Knob	20057330
31	Case Assembly	20132153
90	Fuse	R3478
724	Calibration screwdriver	R2455

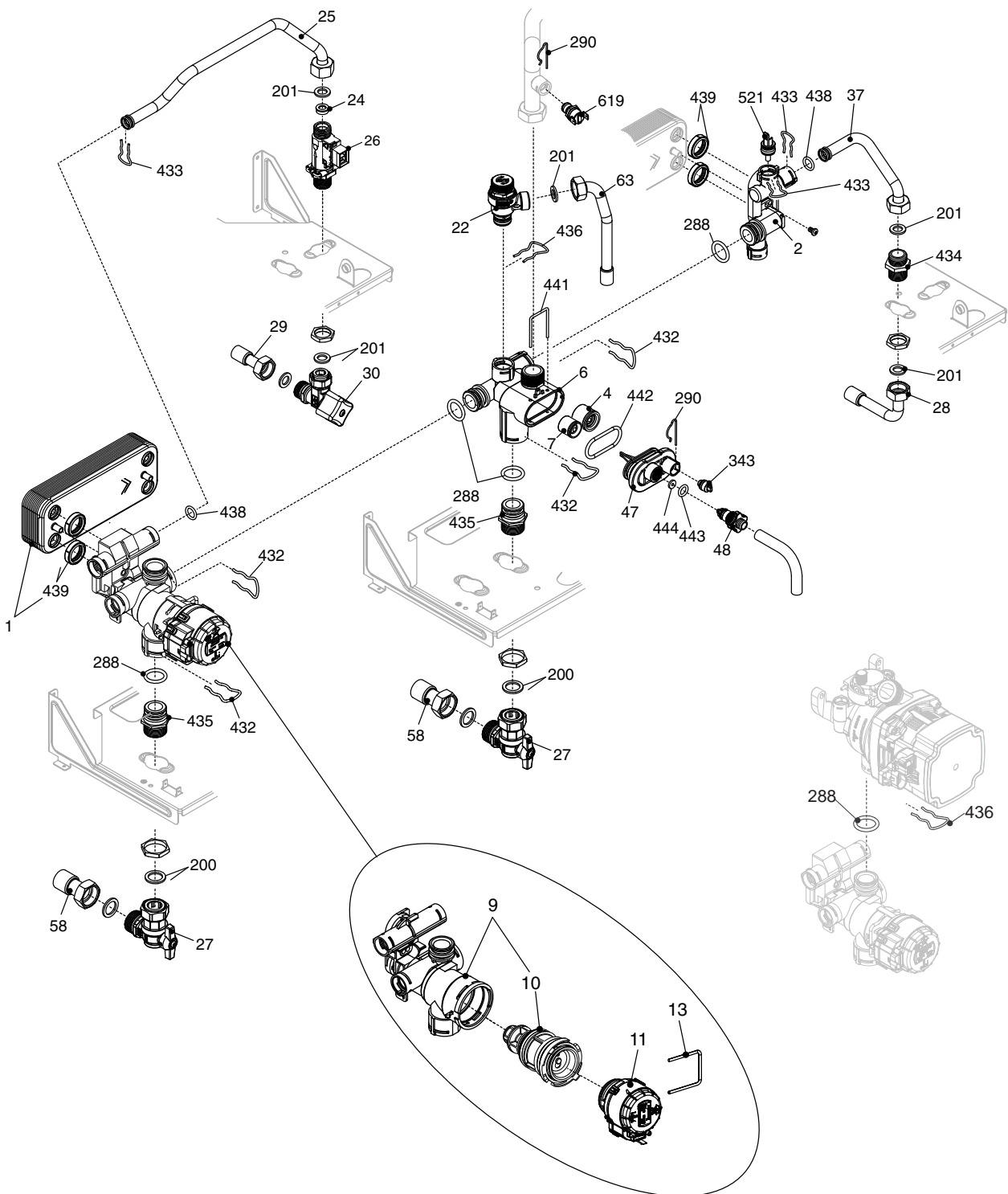

POS.	DESCRIPTION	29
1	Exchanger	R8037
2	Connection	R10030114
4	Non return valve	R10025056
6	By-pass casing	R10024641
7	High head by-pass valve	R1552
9	3-way heating manif.+cartridge	20021496
10	Cartridge	20043594
11	Actuator	20017594
13	Clip	20017598
22	Safety valve	20043820
24	Flow governor	R10024987
25	Pipe	20011423
26	Dhw actuator	20073700
27	3/4" heat water cock	R1592
28	Pipe	20025758
29	Pipe	20025756
30	Water supply stop cock	R1888
37	Pipe	R10025840
47	Cover for by-pass assembly	R10024643
48	Cock	R10024646
58	Pipe	20025757
63	Pipe	20025755
200	Washer	R5023
201	Washer	R5026
288	O ring	R6898
290	Clip	R2165
343	Pump plug	R2216
432	Clip	R10024958
433	Clip	R10024986
434	Nipple	R10024985
435	Fitting/union	R10025059
436	Clip	R10025062
438	O ring	R10024988
439	Washer	R10025067
441	Clip	R10025063
442	O ring	R10025065
443	O ring	R10025064
444	Washer	R10025066
521	NTC sensor	R10027351
619	Pressure	20003181

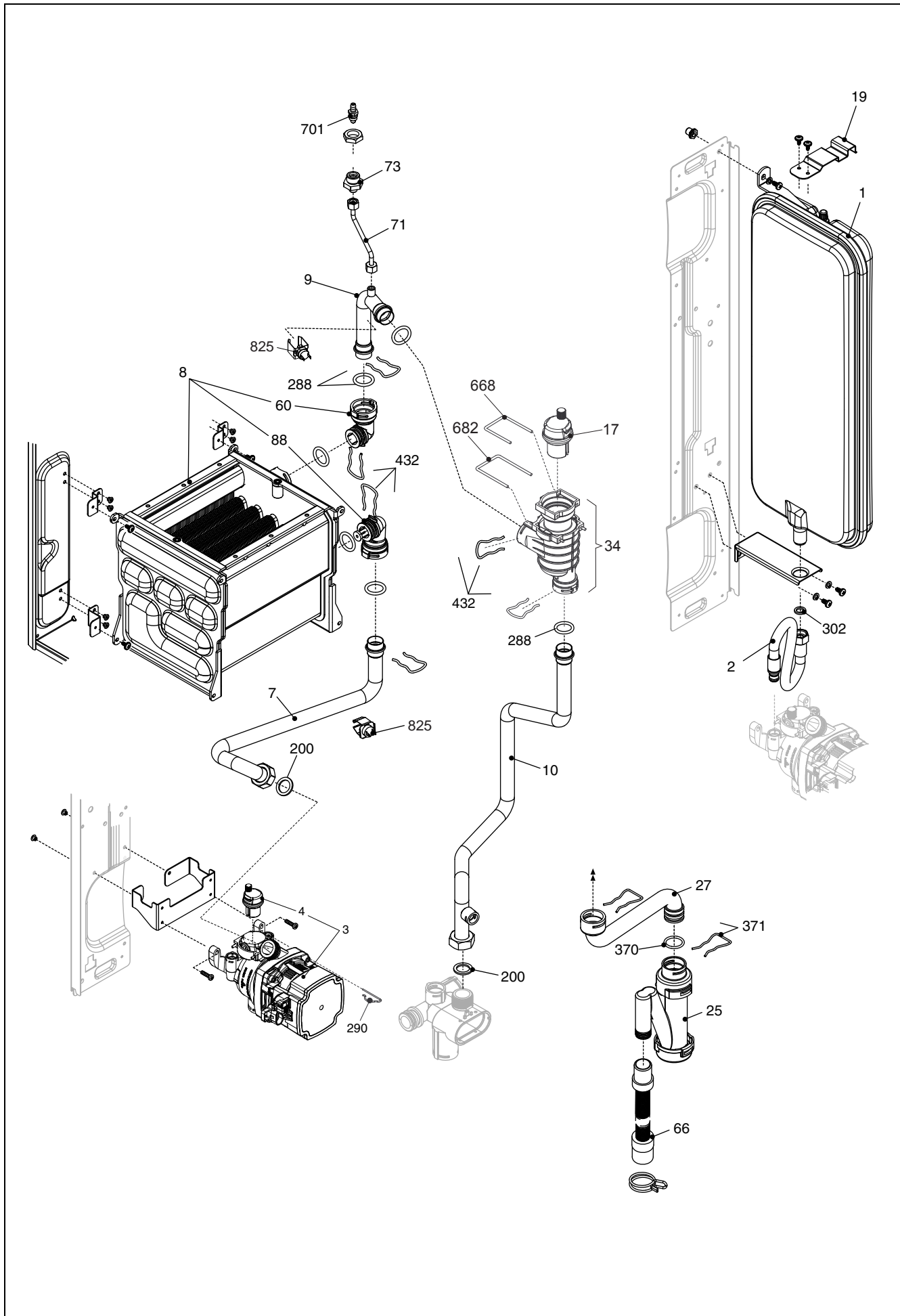

POS.	DESCRIPTION	29
1	Expansion vessel	20029826
2	Pipe	R10028603
3	Pump	20099105
4	Air vent bottle	R10025485
7	Pipe	20025763
8	Condensing exchanger assembly	20039924
9	Pipe	20090680
10	Pipe	20025744
17	Air vent valve	20019768
19	expansion vessel bracket	20125261
25	Siphon	20025733
27	Condensation outlet tube kit	20025743
34	Degasser kit	20032553
60	Connection	20039953
66	Flexible pipe	R10027545
71	Pipe	20025746
73	Cock	R10028431
88	Connection	20039954
200	Washer	R5023
288	O ring	R6898
290	Clip	R2165
302	Washer	R5025
370	O ring	R10023533
371	Clip	R10023532
432	Clip	R10024958
668	Clip	20019767
682	Clip	20120828
701	Vent plug	R10023235
825	NTC Detector	20078350

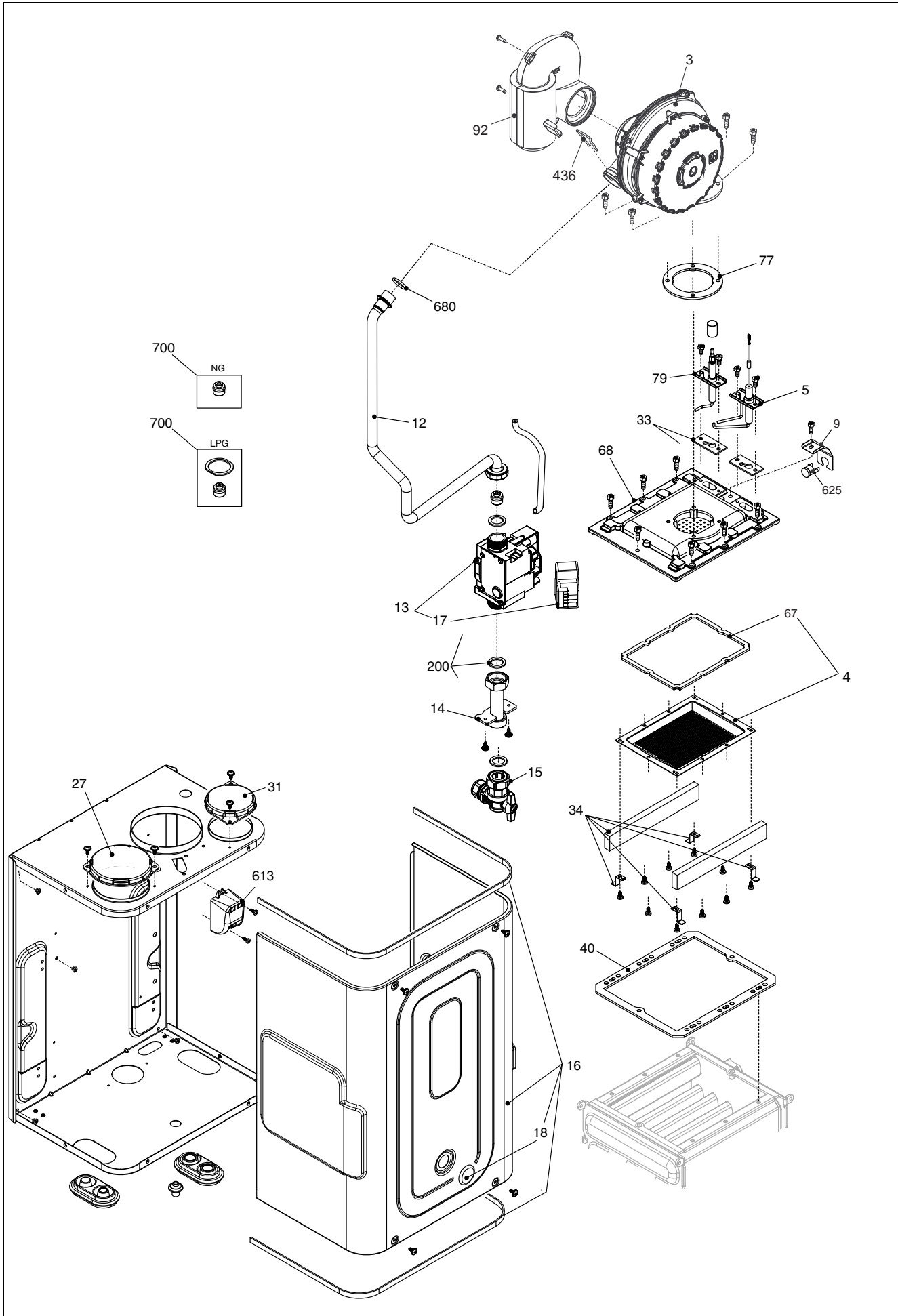



POS.	DESCRIPTION	29
3	Integrated fan	20081318
4	Burner	20055216
5	Spark ignition electrode	20025737
9	Clip	20093799
12	Pipe	20025745
13	Gas valve	20039202
14	Gas pipe	20005553
15	3/4" gas cock	R2266
16	Combustion chamber cover	20005594
17	Gas valve solenoid	20040675
18	Plug	20005550
27	Hole cover	20005586
31	Hole cover	20049606
33	Electrode seal	20025740
34	Protection	20046270
40	Heat exchanger seal (29kw)	20046265
67	Burner seal (29kw)	20116625
68	Cover	20046266
77	Washer	20025753
79	Flame sensor electrode	20043523
92	Silencer	20025760
200	Washer	R5023
436	Clip	R10025062
613	Ignition transformer	20001563
625	High limit thermostat	20005585
680	Washer	20024869
700	Ng conversion kit (up to serial n. $\leq$ 20099225L4253916)	20057751
700	Ng conversion kit (from serial n. $\geq$ 20099225L4253917)	20113104
700	LPG conversion kit (up to serial n. $\leq$ 20099225L4253916)	20029055
700	Lpg conversion kit (from serial n. $\geq$ 20099225L4253917)	20113110

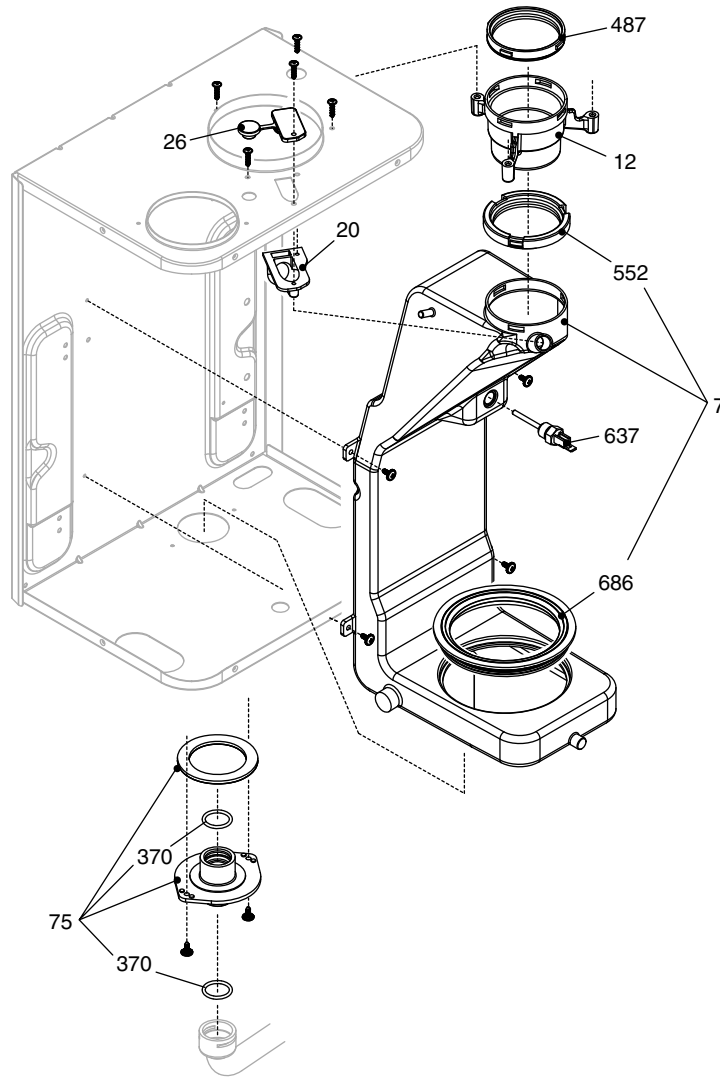

POS.	DESCRIPTION	29
7	Conveyor	20026060
12	Flue drain connection	R10028421
20	Outlet nut	20026049
26	Plug	20026058
75	Flue clector	20026056
370	O ring	R10023533
487	Washer Ø 60	R10026345
552	Washer Ø 60	R10028426
637	Flue sensor	20007050
686	Washer	20026059

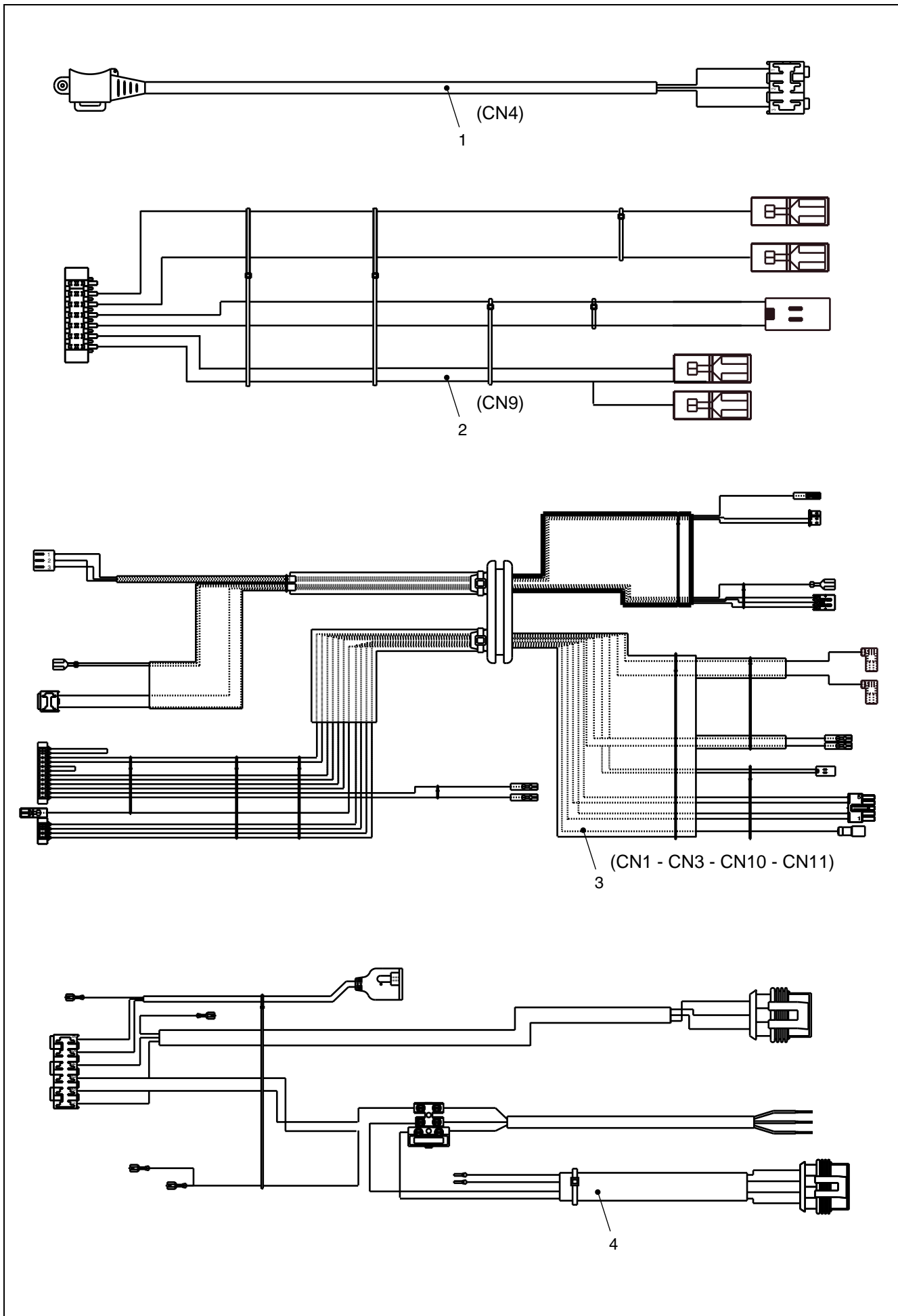

POS.	DESCRIPTION	29
1	Hydraulic control cable	20017596
2	Low tension cable	20113021
3	Combustion cable	20025736
4	Power wiring harness	20101723

<b>Rev.</b>	<b>Data</b>	<b>Descrizione</b>
1.0	23/11/2015	E00120150290 : tappo degas. 2 fori – E00120150787 : diaframma , kit trasformazioni Inserita nuova tavola per gestione disegni cablaggi elettrici
2.0	10/02/2016	Aggiornato disegno caldaia copertina – Aggiunta guarnizione bruciatore E00120150854: cablaggio bassa tensione
3.0	06/12/2016	Corrette trasformazioni gas (e gestione matricola)rif.E00120150787– aggiunta staffa fiss.vaso esp. Corretto disegno coperchio camera combustione – aggiunta molletta fissaggio tappo degasatore
4.0	22/02/2017	Aggiornato codice mantello – E00120170040 : Nuovo Brand Vokera by Riello



---

Vokera reserve the right to change the specifications without prior notice.  
Consumers' statutory rights are not affected.