



Zenith Solar thermal 11m pump station Installation manual

Product code: 20009196



WATER FLOW AND RETURN GROUP

This instruction manual is an integral part of the installation and maintenance manual for the complete solar water heating system. Refer to that manual for **GENERAL SAFETY INFORMATION AND PRECAUTIONS**.

DESCRIPTION

The **WATER GROUP TOP 6,5M** cod. 20009197 and the **WATER GROUP TOP 11M** cod. 20009196 allows you to connect a solar storage cylinder to a series of solar collectors. The group allows you to perform flow adjustment, flushing, circuit filling and draining, and pump replacement far more easily. The compact safety valve group contains, in addition to the safety valve itself, a pressure gauge and a fitting for connecting a hose to the expansion vessel. The water inlet group also incorporates a non-return valve.

Versions with a solar regulator are also equipped with an electronic control unit for controlling the associated solar heating system.

CONTENTS

Description

- Water flow and return group (1)
- Fixing screws (2)
- Solar regulator (if provided) (3)
- Sensors (if provided) (4)
- Instruction leaflet (5)

Q.ty

- 1
- 2
- 1
- 3
- 1

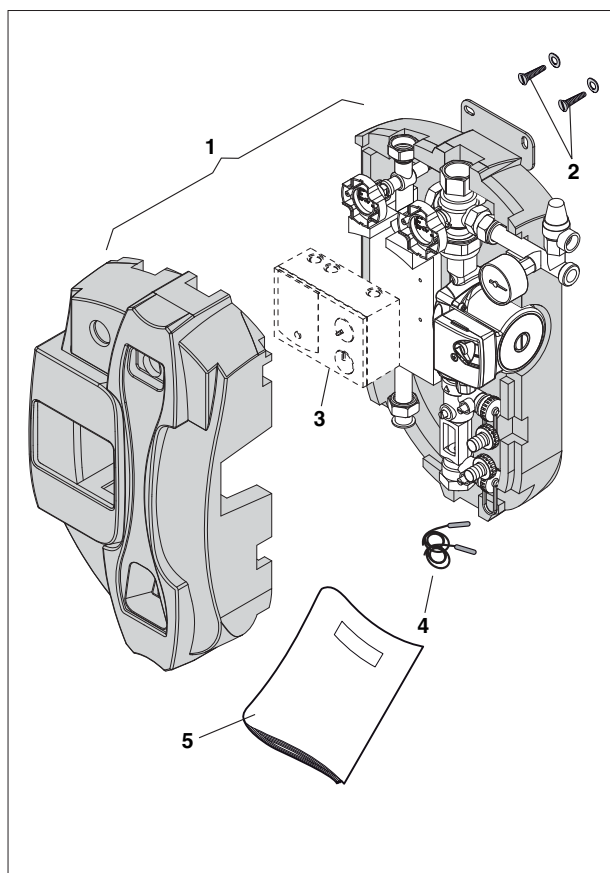

INSTALLATION

Positioning the water control group

- Position the water control group on the storage cylinder and fix it in place with the screws (2).
If you are fixing the water control group on a wall, make sure that you use the right type of wall plugs.

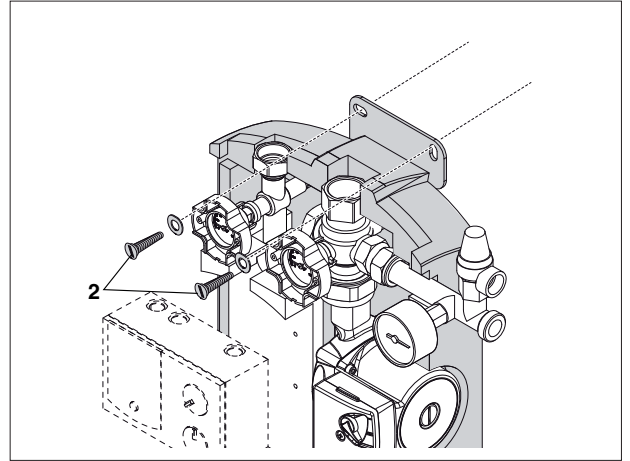

- Connect the safety valve drain to a pipe (T) to avoid burns from expelled fluid and to permit the heat transfer fluid to be recovered.
- Connect up the expansion vessel (E), which is designed for use in solar water heating systems.
- Connect the pump and the sensors to the solar regulator (if provided) as instructed in the manual supplied with the regulator.

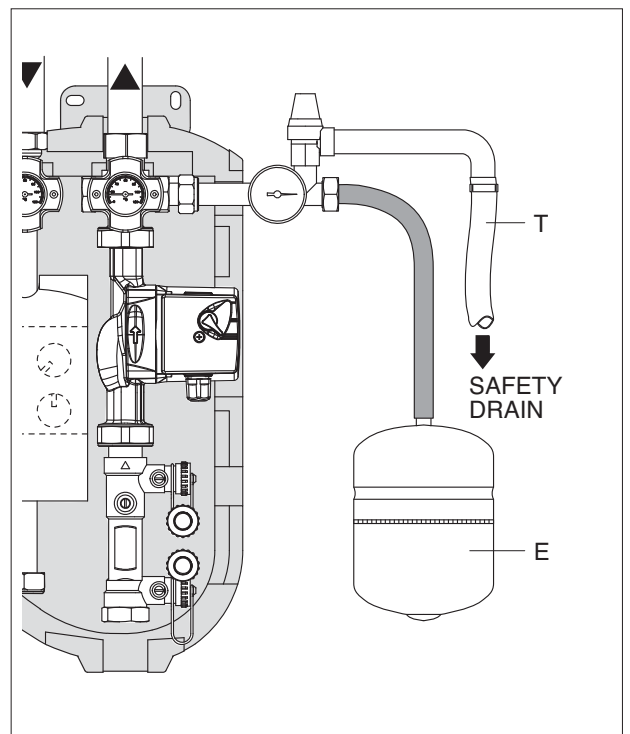

DESIGN

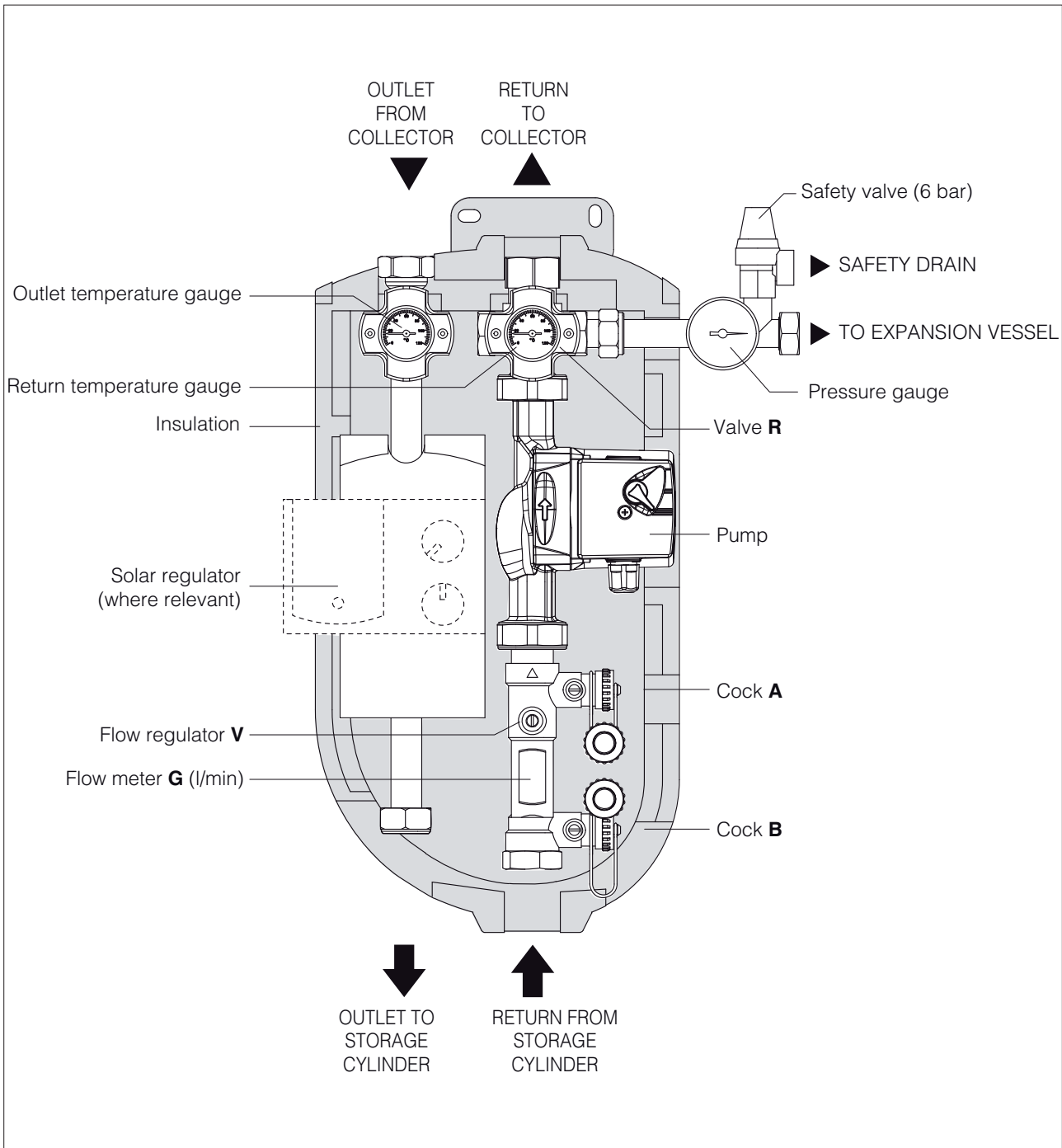

FUNCTIONING

FLUSHING THE SYSTEM

- Turn the knob of the return valve (R) fully anti-clockwise.
- Close the flow regulator (V) (so that the screw slot is horizontal).
- Open the cocks (A) and (B) on the return group.
- Pump water in through the cock (A) and wait for it to come out of the cock (B).
Leave water flow through the system until it has been thoroughly flushed out.
- Close the cocks (A) and (B) and re-open the flow regulator (V) (so that the screw slot is vertical).

⚠ If copper piping has been used and joints have been hot brazed, flush out the system to remove any brazing residues. Seal test the system after you have flushed it out.

⚠ Fill the solar collector with water/glycol mix immediately after flushing it out, because flushing water may remain trapped in the circuit (with a consequent risk of freezing).

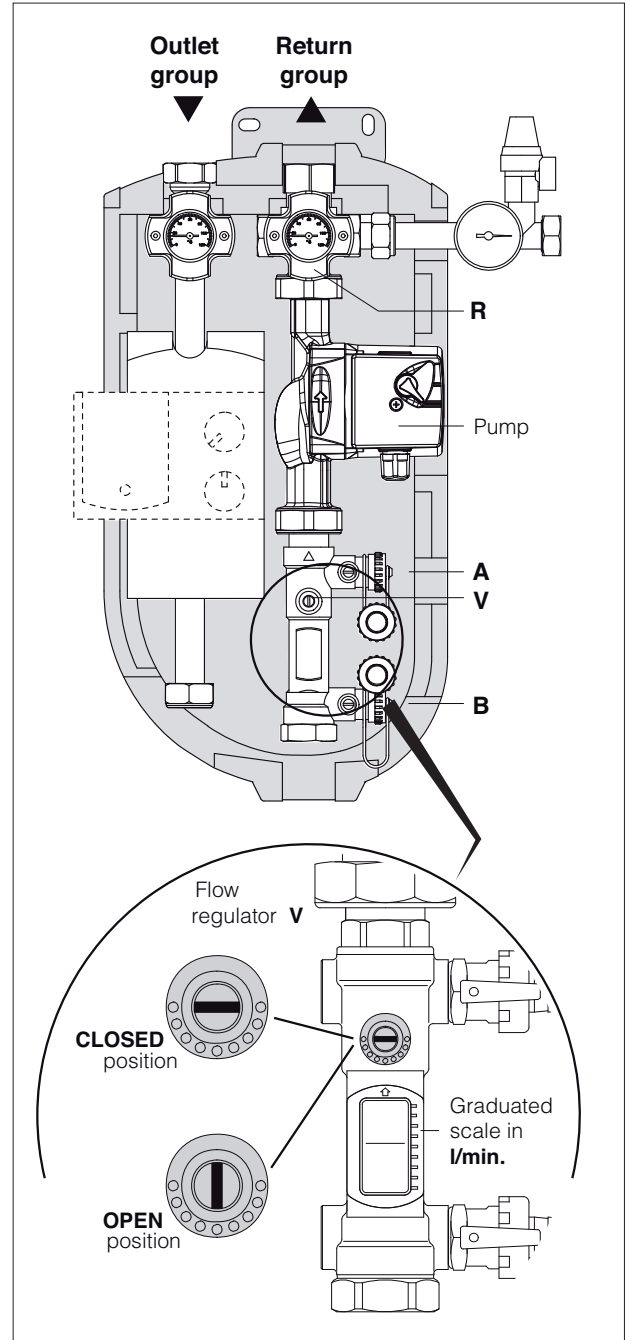

PREMIXING WATER + GLYCOL

Glycol anti-freeze is supplied separately and must be premixed with water in a suitable container before being used to fill the system. For example, a mix of 40% glycol and 60% water provides anti-freeze protection down to a temperature of -21°C.

⚠ The propylene glycol supplied is specially formulated for solar collector applications and remains fully efficient throughout the -32 to +180°C temperature range. It is also non-toxic, biodegradable and biocompatible.

⚠ Do NOT part fill the circuit with pure glycol then add water later.

Anti-freeze	Temperature	Density
50%	-32°C	1,045 kg/dm ³
40%	-21°C	1,037 kg/dm ³
30%	-13°C	1,029 kg/dm ³

⚠ Do not use automatic or manual filling systems.

⚠ If the water supply is highly chlorinated, use distilled water to prepare the glycol/water mix.

FILLING THE CIRCUIT

Step 1

Turn the knob of the return valve (R) fully anticlockwise. Close the flow regulator (V) (so that the screw slot is horizontal).

Step 2

Open, if necessary, the manual bleed valve at the highest point in the system and keep it open throughout the filling operation.

Step 3

Pump the heat transfer fluid around the circuit with an external filling pump until all air bubbles have been eliminated. Close, if it was opened, the manual bleed valve at the highest point in the system.

Step 4

Temporarily raise the pressure in the system to 4 bar.

Step 5

Start up the system for about 20 minutes.

Step 6

Repeat the air bleed operation from step 2 on until all residual air is eliminated from the circuit.

Step 7

Set the pressure in the system to 3 bar.

Step 8

Close the cocks (A) and (B) and re-open the flow regulator (V).

⚠ Do not fill the system in bright, sunny conditions or if the collectors are hot.

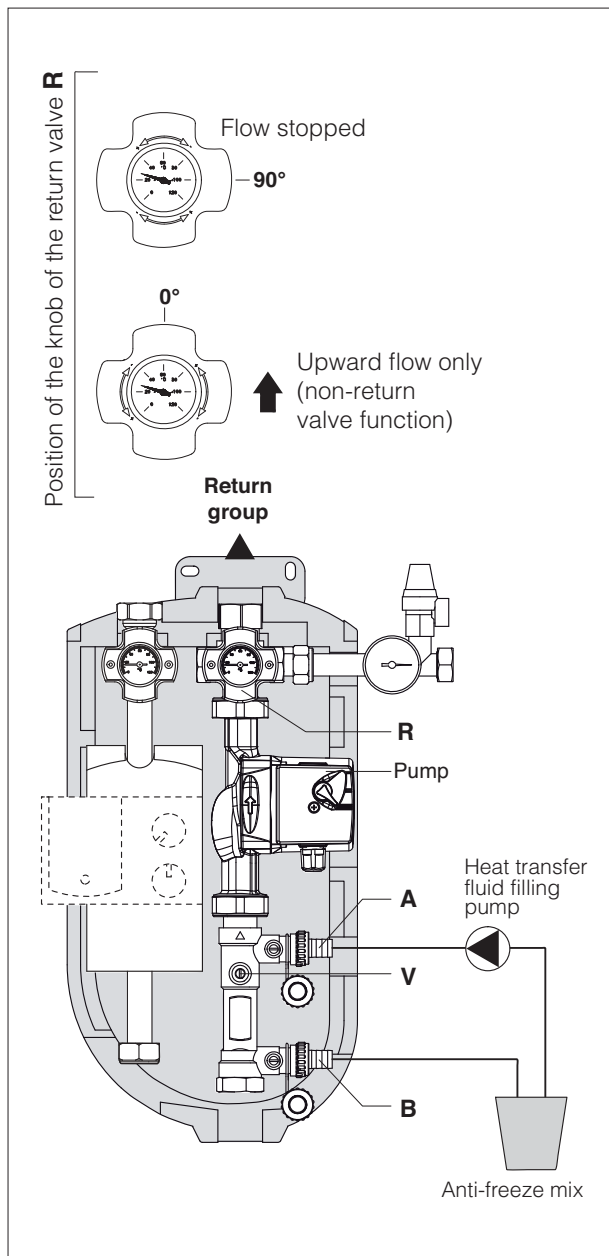

ADJUSTING THE FLOW

Correct flow adjustment is essential to proper functioning of the entire system.

To achieve the best possible flow and reduce wastage, you need to find the right balance between the speed of the filling pump (C) and the adjustment made on the flow regulator (V).

Proceed as follows:

- Fully open the flow regulator (V) and adjust the pump (C) to minimum speed (I).
- Read the flow rate from flow meter (G) and compare it with the flow rate specified for the system (see the table below for systems incorporating solar collectors).

N° of collectors	Required flow in l/min.
2	2 ÷ 3
3	3 ÷ 4
4	5 ÷ 6
5	6 ÷ 7
6	7 ÷ 8

- If the required flow rate is below that currently measured in the circuit, close the flow regulator (V) gradually (turning it clockwise) until the correct value is achieved.
- If the required flow rate is above that currently measured in the circuit, increase the speed of the pump (C), then read off the new measured flow rate and repeat the previous step.

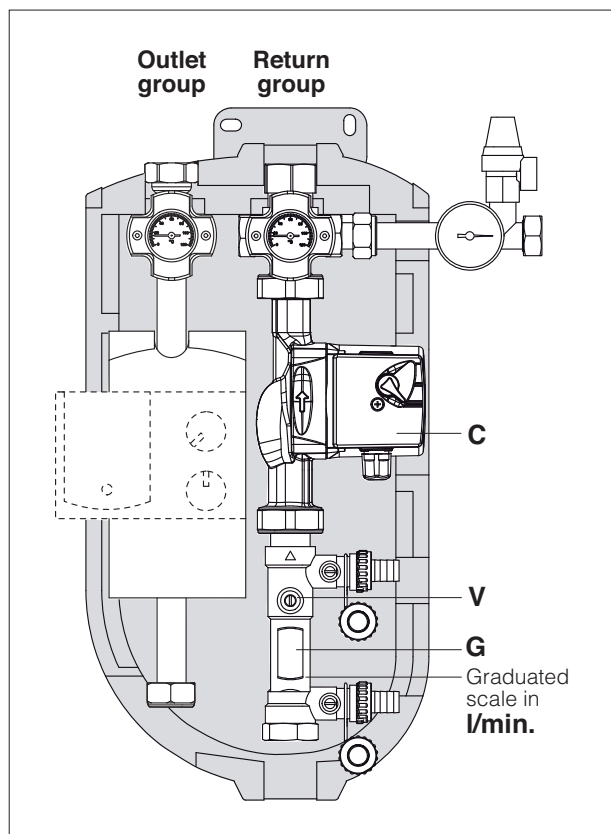

PUMP TOP 6,5 m

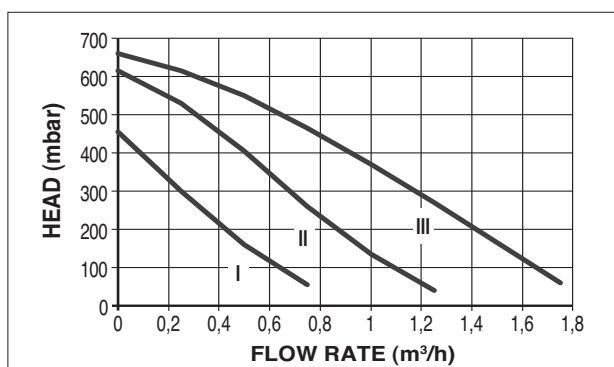

PUMP TOP 11 m

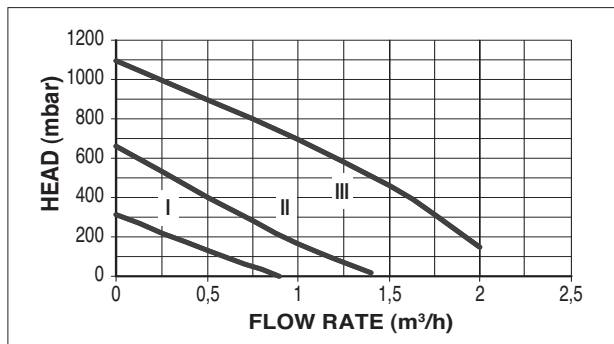

VALVE GROUP pressure drop

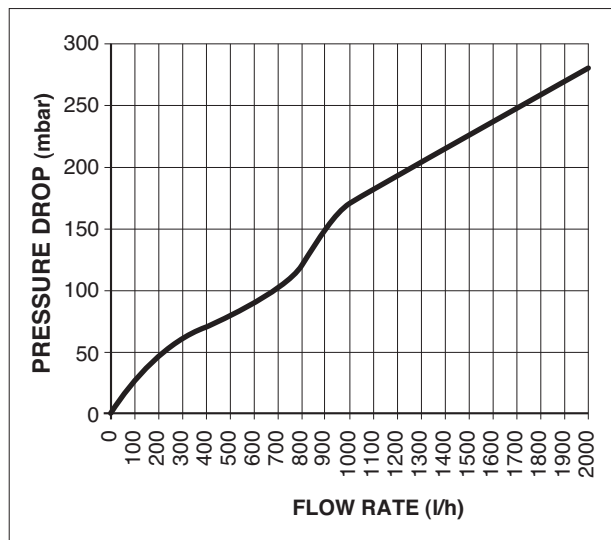

REPLACING THE PUMP

Before starting work to replace the pump (C):

- Switch the electricity supply to the storage cylinder's valve group and to any associated boiler OFF at the main switch and at the control panel.

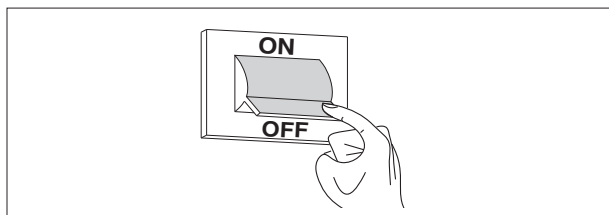

- Close the flow regulator (V).
- Turn the return valve knob 90° clockwise to close the return valve (R).
- Unscrew the ring nuts H1 and H2 and remove the pump (C).

Reverse the above steps to fit the new pump.

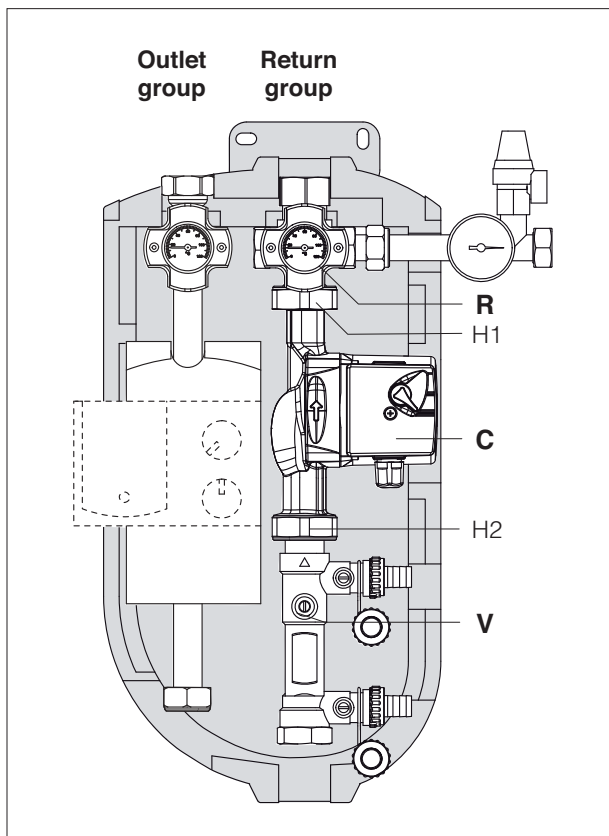

ENGLISH

CHECKS

On completion of the installation, perform the checks listed in the table below.

DESCRIPTION	OK
Water circuit	
No automatic or manual filling pumps	
Safety valve calibrated to 6 bar, and no shut-off valves between it and the collectors	
Drain line from safety valve follows suitable path	
Expansion vessel correctly located and pre-charged to 2.5 bar	
Water return group installed in return line	
Solar circuit delivery line connected to the top of the solar storage cylinder coil	
Non-return valve activated as gravity brake	