

# Zenith Solar tile roof connection joint installation manual

## Three and more Inset collectors



# KIT SUPPLÉMENTAIRE D'ENCASTREMENT POUR CAPTEURS À CHÂSSIS

## ADDITIONAL RECESSED FLASHING KIT FOR FRAME MOUNTED COLLECTORS

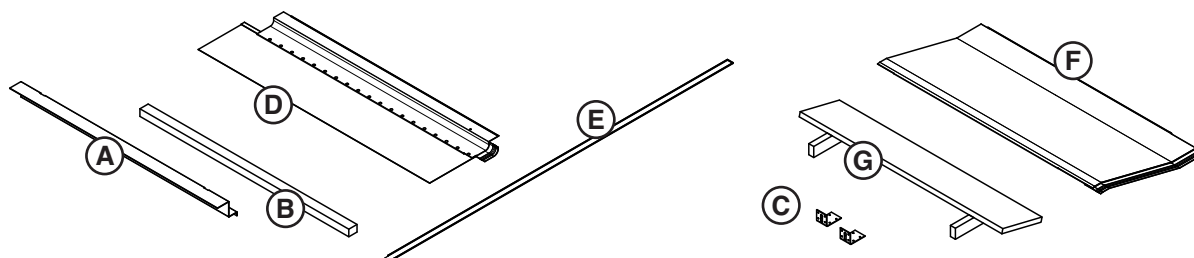

Réf.	Description	Q.té
A	PATTE INFÉRIEURE L = 1261 mm	1
B	POUTRELLE EN BOIS	1
C	PATTE EN « L » 60x90x2	2
D	TOLE DE RECOUVR. INFÉRIEURE CENTRALE L=1305 mm	1
E	BAGUETTE CENTRALE L=2087 mm	1
F	TOLE DE RECOUVR. SUPERIEURE CENTRALE L=1305 mm	1
G	BASE DE SUPPORT	1
-	CLOUS 2,5x25	4
-	ATTACHES	4
-	VIS AUTOPERCEUSES ÉTANCHES (CALOTTE)	1
-	MOUSSE 20x50 L=1500 mm	1
-	VIS H M8x16 - 8.8 UNI 5739	2
-	VIS À BOIS 4x40	7
-	GOUJON FILETÉ M8x40 Tête six pans creux	2
-	VIS À BOIS 5x80	2
-	ÉCROUS M8	2
-	RONDELLES M8	4
-	NOTICE D'INSTRUCTIONS	1

Pos.	Description	Q.ty
A	BOTTOM BRACKET L = 1261 mm	1
B	WOODEN BATTEN	1
C	"L" SHAPED BRACKET 60x90x2	2
D	CENTRAL BOTTOM FLASHING PLAT L=1305 mm	1
E	CENTRAL PROFILE L=2087 mm	1
F	CENTRAL TOP FLASHING PLAT L=1305 mm	1
G	SUPPORT WEDGES	1
-	NAILS 2,5x25	4
-	FLASHING CLIPS	4
-	SELF-TAPPING SCREWS WITH SEALS (CAPS)	1
-	SPONGE 20x50 L=1500 mm	1
-	HEX HEAD SCREW M8x16 - 8.8 UNI 5739	2
-	WOOD SCREW 4x40	7
-	THREADED ALLEN STUD, M8x40	2
-	WOOD SCREW 5x80	2
-	NUTS M8	2
-	WASHERS M8	4
-	INSTRUCTION MANUAL	1

## Dimensions et associations / Dimensions and combinations

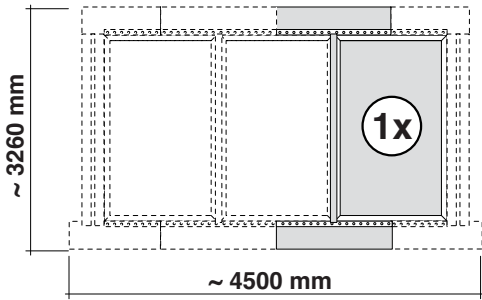

		Nbre de capteurs Nr. of collectors					
		1	2	3	4	5	6
KIT D'ENCASTREMENT POUR 1 CAPTEUR FLASHING KIT FOR 1 COLLECTOR	20010353	1x					
KIT D'ENCASTREMENT POUR 2 CAPTEURS FLASHING KIT FOR 2 COLLECTORS	20010393	1x	1x	1x	1x	1x	
KIT D'ENCASTREMENT SUPPLÉMENTAIRE POUR 2 CAPTEURS ADDITIONAL FLASHING KIT FOR 2 COLLECTORS	20010447			1x	2x	3x	4x

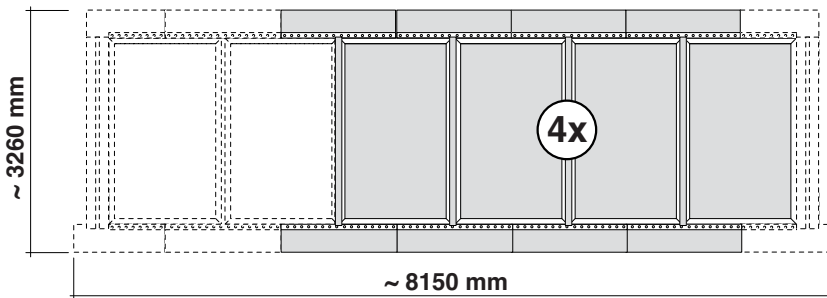
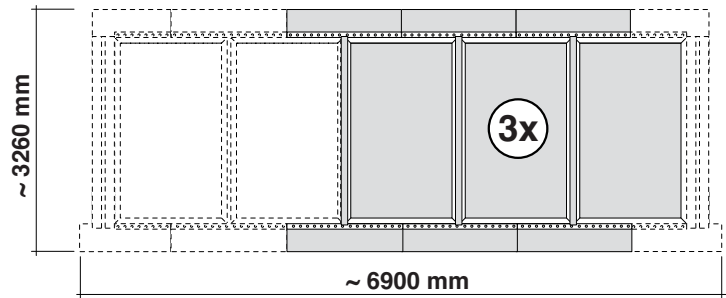
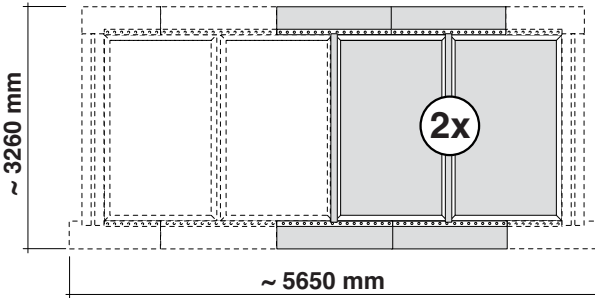

Les mesures présentes sur la figure indiquent l'encombrement total du kit monté.

The dimensions in the figure above show the total size of the kit once installed.

## Montage / Installation

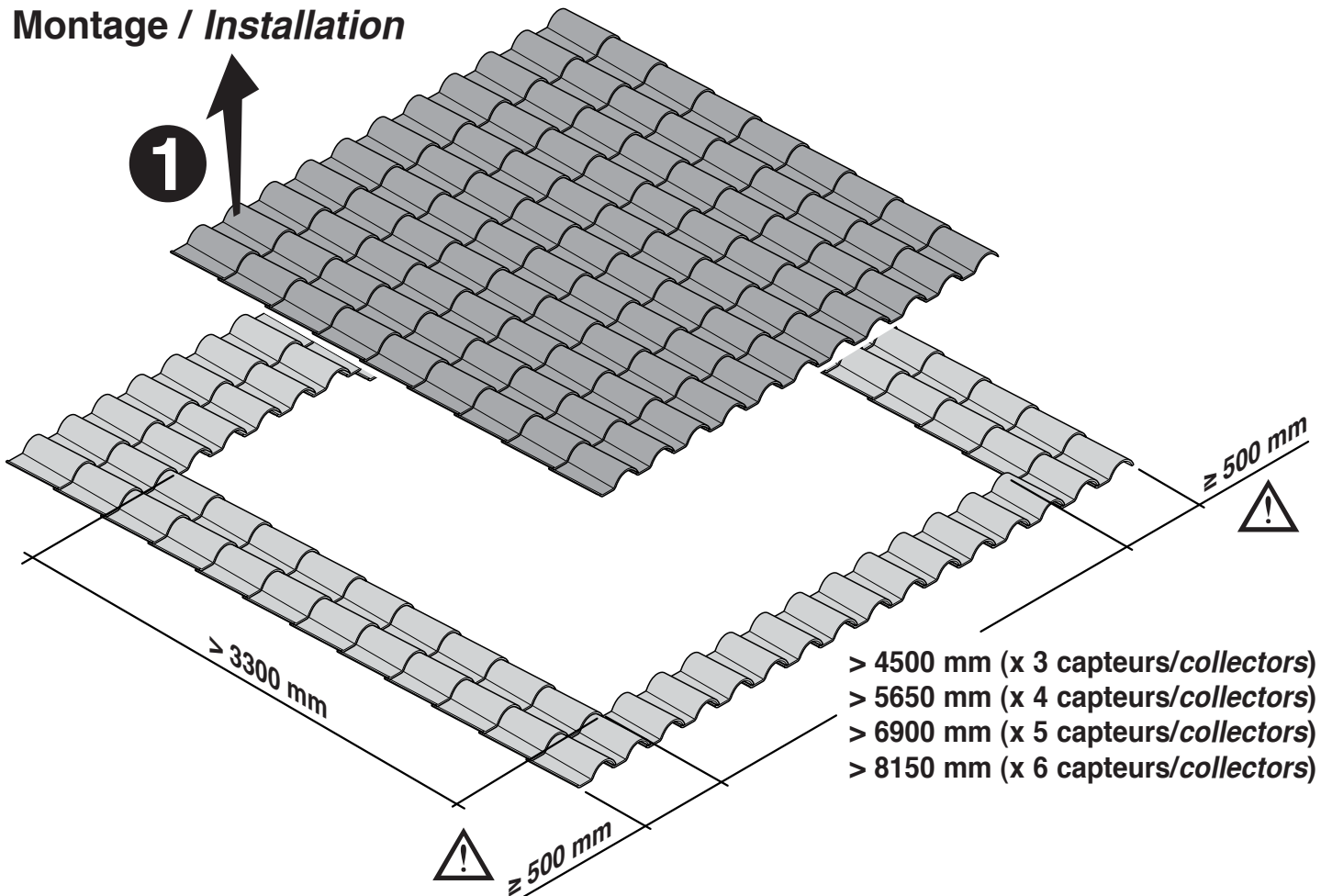



## ASSOCIATION avec KIT D'ENCASTREMENT POUR 2 CAPTEURS COMBINATION with RECESSED FLASHING KIT FOR 2 FRAME MOUNTED COLLECTORS

Procéder à l'installation des divers composants en respectant la séquence illustrée ci-dessous.  
*Install the various components of the additional flashing kit in the sequence illustrated below.*

Pour les détails de chaque phase, se référer aux instructions contenues dans le KIT D'ENCASTREMENT POUR 2 CAPTEURS.

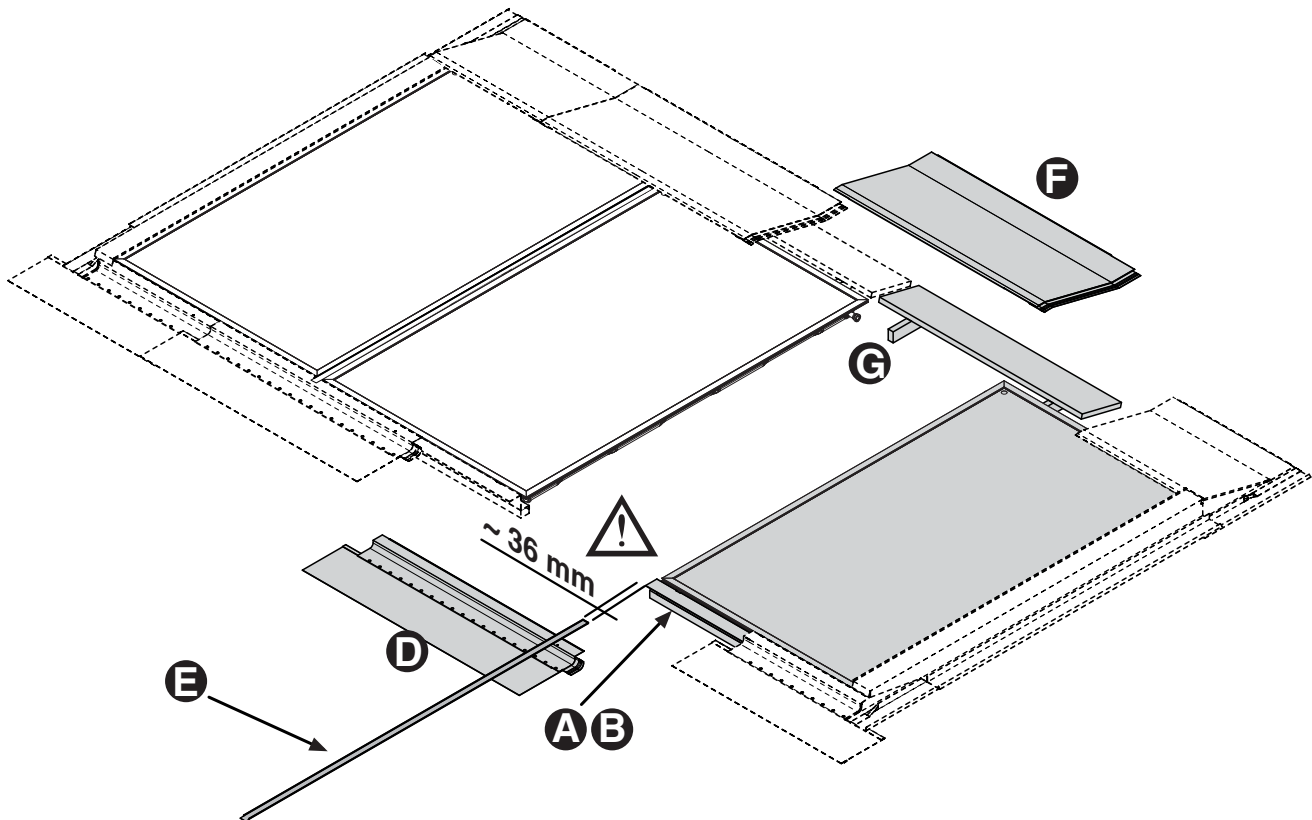
*Refer to the instruction manual provided with the RECESSED FLASHING KIT FOR 2 FRAME MOUNTED COLLECTORS for details on how to install that kit.*



 Une fois les capteurs positionnés sur le toit, les couvrir avant de passer à l'installation des tôles de recouvrement.  
*Cover the collectors as soon as they have been installed on the roof, before installing the flashing.*

 TOUS LES SERRAGES HYDRAULIQUES SUR LES CAPTEURS DOIVENT SE FAIRE SELON LE SYSTÈME CLÉ/CONTRE-CLÉ.  
*ALWAYS USE TWO WRENCHES WHEN TIGHTENING HYDRAULIC UNIONS. HOLD THE ONE UNION STEADY WHILE TURNING THE OTHER.*